

Cree® XLamp® LED Soldering & Handling

XLamp XP Family LEDs

This application note applies to XLamp XP Family LEDs: XLamp XP-C, XP-E & XP-G LEDs, which have order codes in the following format:

XPXXXX-XX-XXXX-XXXXXX

This application note explains how XLamp XP Family LEDs and assemblies containing these LEDs should be handled during manufacturing. Please read the entire document to understand how to properly handle XLamp XP Family LEDs.

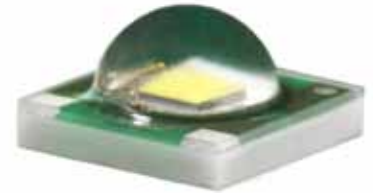

Table of Contents

Handling XLamp XP Family LEDs	1
Circuit Board Preparation & Layouts	3
Case Temperature (T _s) Measurement Point	3
Notes on Soldering XLamp XP Family LEDs.....	4
Moisture Sensitivity	5
XLamp XP Family LED Reflow Soldering Characteristics	6
Chemicals & Conformal Coatings	7
Assembly Storage & Handling.....	8
Mechanical Drawings: Tape and Reel	9
Mechanical Drawings: Packaging & Labels	10

Handling XLamp XP Family LEDs

Manual Handling

Use tweezers to grab XLamp XP Family LEDs at the base. Do not touch the lens with the tweezers. Do not touch the lens with fingers. Do not push on the lens.

✓
CORRECT

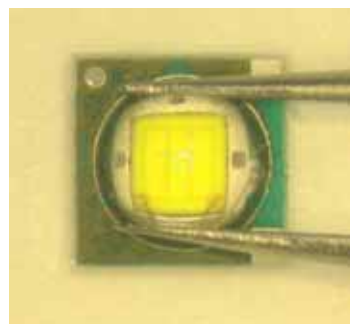
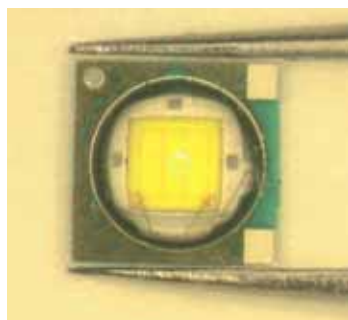

✗
WRONG



Cree recommends the following at all times when handling XLamp XP Family LEDs or assemblies containing these LEDs:

- Avoid putting mechanical stress on the LED lens.
- Never touch the optical surface with fingers or sharp objects. The LED lens surface could be soiled or damaged, which would affect the optical performance of the LED.

Whenever possible, Cree recommends the use of one of the following pick & place tools to remove XLamp XP Family LEDs from the factory tape & reel packaging.

Pick & Place Nozzle #1

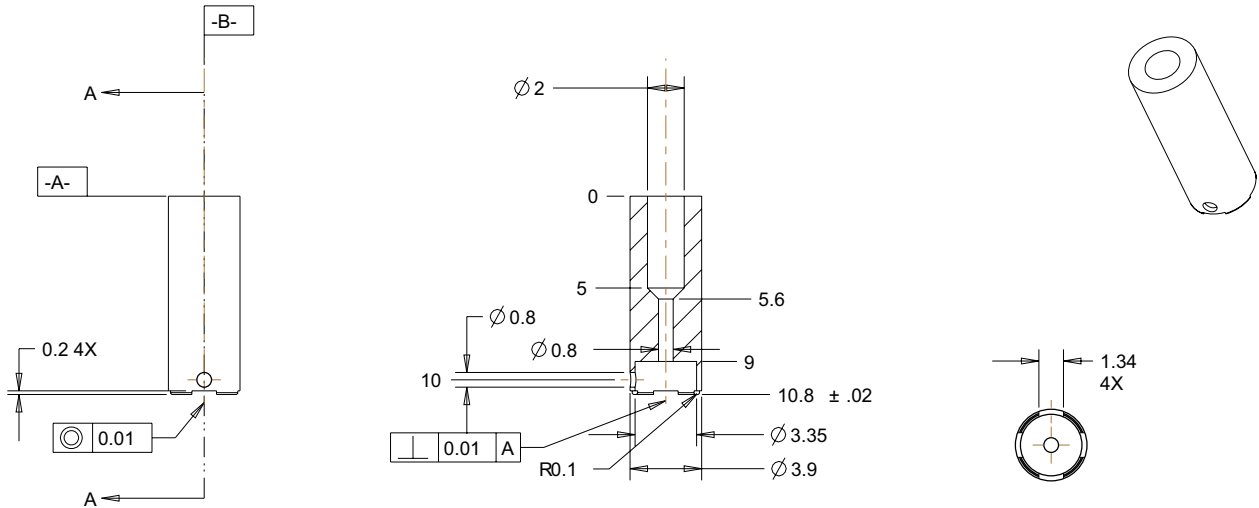

Pick & Place Nozzle #2

All dimensions in mm

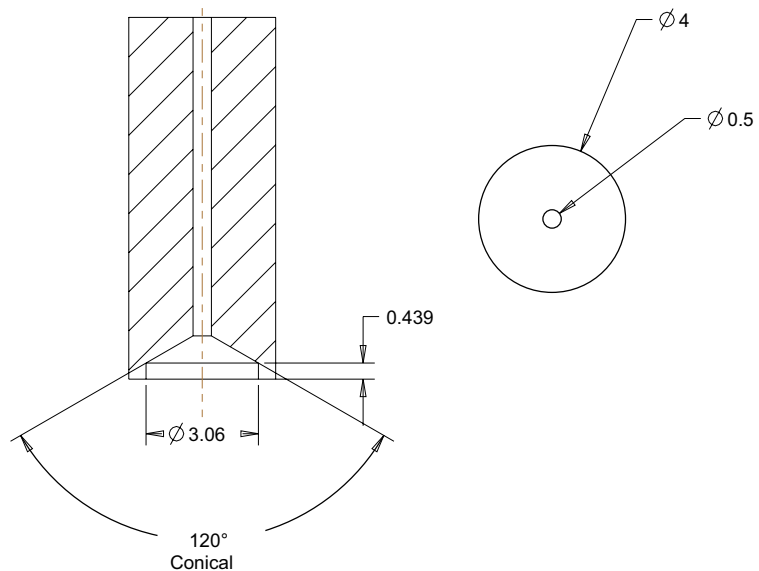

This document is provided for informational purposes only and is not a warranty or a specification. For product specifications, please see the data sheets available at www.cree.com. For warranty information, please contact Cree Sales at sales@cree.com. Copyright © 2008-2009 Cree, Inc. All rights reserved. The information in this document is subject to change without notice. Cree, the Cree logo and XLamp are registered trademarks of Cree, Inc. Other trademarks, product and company names are the property of their respective owners and do not imply specific product and/or vendor endorsement, sponsorship or association.

Cree, Inc.
4600 Silicon Drive
Durham, NC 27703
USA Tel: +1.919.313.5300
www.cree.com/xlamp



Circuit Board Preparation & Layouts

Printed circuit boards (PCBs) should be prepared and/or cleaned according to the manufacturer's specifications before placing or soldering XLamp XP Family LEDs onto the PCB.

The diagram below shows the recommended PCB solder pad layout for XLamp XP Family LEDs.

All dimensions in mm

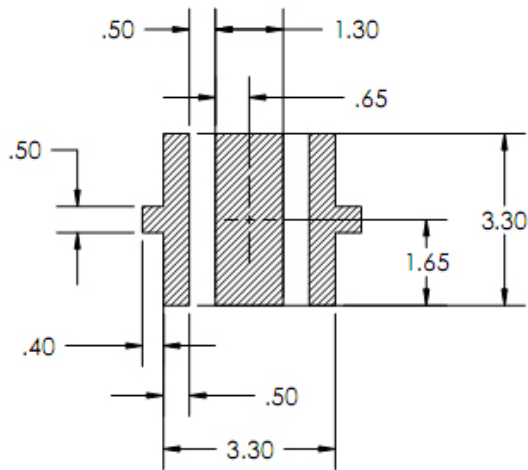

Recommended PCB Solder Pad

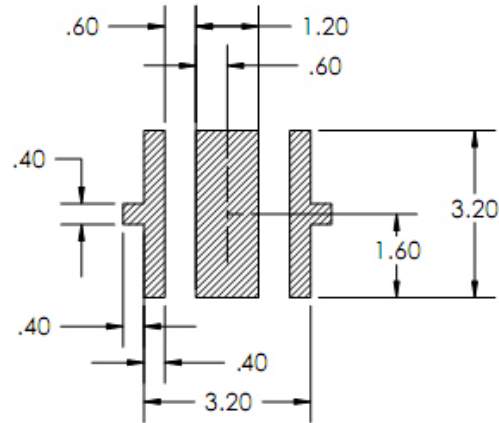

Recommended Stencil Pattern
(hatched area is opening)

Case Temperature (T_s) Measurement Point

XLamp XP Family LED case temperature (T_s) should be measured on the PCB surface, as close to the LED's thermal pad as possible. This measurement point is shown in the picture below.

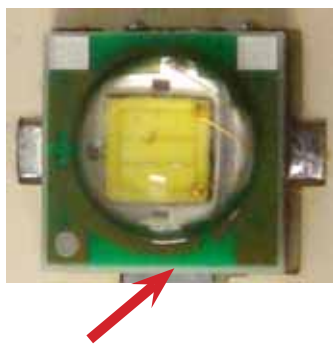

It is not required to use a solder footprint for the thermal pad that is larger than the XLamp XP Family LED itself. In testing, Cree has found such a solder pad to have insignificant impact on the resulting T_s measurement.



Notes on Soldering XLamp XP Family LEDs

XLamp XP Family LEDs are designed to be reflow soldered to a PCB. Reflow soldering may be done by a reflow oven or by placing the PCB on a hotplate and following the reflow soldering profile listed on the previous page.

Do not wave solder XLamp XP Family LEDs. Do not hand solder XLamp XP Family LEDs.

✓
CORRECT



✓
CORRECT



⊘
WRONG

Solder Paste Type

Cree strongly recommends using “no clean” solder paste with XLamp XP Family LEDs so that cleaning the PCB after reflow soldering is not required. Cree uses the following solder paste internally:

- Indium Corporation of America® Part number 82676
- Sn62/Pb36/Ag2 composition
 - Flux: NC-SMQ92J

Cree recommends the following solder paste compositions: SnPbAg, SnAgCu and SnAg.

Solder Paste Thickness

The choice of solder and the application method will dictate the specific amount of solder. For the most consistent results, an automated dispensing system or a solder stencil printer is recommended. Cree has seen positive results using solder thickness that results in a 3-mil (75- μ m) bond line.

✓
CORRECT

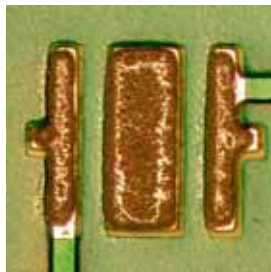

⊘
WRONG



Notes on Soldering XLamp XP Family LEDs (continued)

After Soldering

After soldering, allow XLamp XP Family LEDs to return to room temperature before subsequent handling. Premature handling of the device, especially around the lens, could result in damage to the LED.

Cree recommends verifying the solder process by checking the consistency of the solder bond of several trial PCBs after reflow. After shearing selected devices from the circuit board the solder should appear completely re-flown (no solder grains evident). The solder areas should show minimum evidence of voids on the backside of the package and the PCB.

Cleaning PCBs After Soldering

Cree recommends using "no clean" solder paste so that flux cleaning is not necessary after reflow soldering. If PCB cleaning is necessary, Cree recommends the use of isopropyl alcohol (IPA).

Do not use ultrasonic cleaning.

Moisture Sensitivity

In testing, Cree has found XLamp XP Family LEDs to have unlimited floor life in conditions $\leq 30^{\circ}\text{C}$ / 85% relative humidity (RH). Moisture testing included a 168 hour soak at 85°C / 85% RH followed by 3 reflow cycles, with visual and electrical inspections at each stage.



XLamp XP Family LED Reflow Soldering Characteristics

In testing, Cree has found XLamp XP Family LEDs to be compatible with JEDEC J-STD-020C, using the parameters listed below. As a general guideline, Cree recommends that users follow the recommended soldering profile provided by the manufacturer of solder paste used.

Note that this general guideline may not apply to all PCB designs and configurations of reflow soldering equipment.

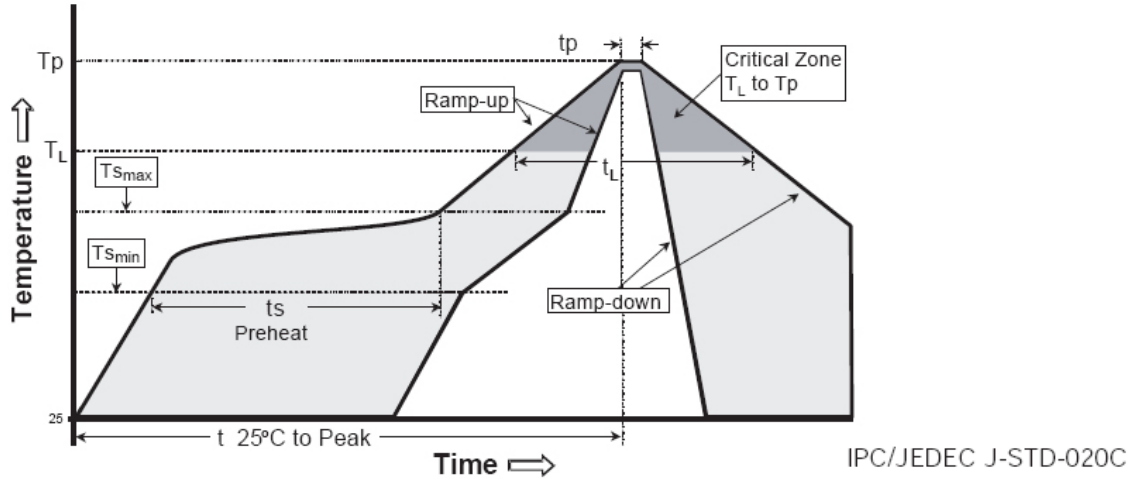

Profile Feature	Lead-Based Solder	Lead-Free Solder
Average Ramp-Up Rate ($T_{s_{max}}$ to T_p)	3°C/second max.	3°C/second max.
Preheat: Temperature Min ($T_{s_{min}}$)	100°C	150°C
Preheat: Temperature Max ($T_{s_{max}}$)	150°C	200°C
Preheat: Time ($t_{s_{min}}$ to $t_{s_{max}}$)	60-120 seconds	60-180 seconds
Time Maintained Above: Temperature (T_l)	183°C	217°C
Time Maintained Above: Time (t_l)	60-150 seconds	60-150 seconds
Peak/Classification Temperature (T_p)	215°C	260°C
Time Within 5°C of Actual Peak Temperature (t_p)	10-30 seconds	20-40 seconds
Ramp-Down Rate	6°C/second max.	6°C/second max.
Time 25°C to Peak Temperature	6 minutes max.	8 minutes max.

Note: All temperatures refer to topside of the package, measured on the package body surface.



Chemicals & Conformal Coatings

Recommended Chemicals

In testing, Cree has found the following chemicals to be safe to use with XLamp XP Family LEDs.

- Water
- Isopropyl alcohol (IPA)
- Arctic Silver & Arctic Alumina brand thermal grease
- 3M Scotch-Weld epoxy adhesive DP-190 (polymeric diamante, kaolin)

Recommended Conformal Coatings

In testing, Cree has found the following conformal coatings to be safe to use with XLamp XP Family LEDs. Conformal coating should not be applied directly to or over the LED lens, as this may affect LED optical performance and reliability.

- Dow Corning 3-1953
- Dow Corning 1-4105
- Dow Corning 1-2577
- Dymax 9-20557
- Humiseal 1H20AR1/S
- Humiseal UV40
- Humiseal 1B51NS
- Humiseal 1B73
- Humiseal 1C49LV
- Shat-R-Shield
- Specialty Coating Systems – Parylene
- TechSpray Turbo-Coat Acrylic Conformal Coating (2108-P)

Chemicals Tested as Harmful

In testing, Cree has found the following chemicals to be harmful to XLamp XP Family LEDs. Cree recommends not using these chemicals anywhere in an LED system containing XLamp XP Family LEDs. The fumes from even small amounts of these chemicals may damage the LEDs.

- Chemicals that might outgas aromatic hydrocarbons (e.g., toluene, benzene, xylene)
- Methyl acetate or ethyl acetate (i.e., nail polish remover)
- Cyanoacrylates (i.e., "Superglue")
- Glycol ethers (including Radio Shack® Precision Electronics Cleaner - dipropylene glycol monomethyl ether)
- Formaldehyde or butadiene (including Ashland PLIOBOND® adhesive)
- Dymax 984-LVUF conformal coating
- Loctite Sumo Glue
- Gorilla Glue
- Clorox bleach
- Clorox Clean-Up Cleaner spray
- Loctite 384 adhesive
- Loctite 7387 activator
- Loctite 242 threadlocker



Assembly Storage & Handling

Do not stack PCBs or assemblies containing XLamp XP Family LEDs so that anything rests on the LED lens. Force applied to the LED lens may result in the lens being knocked off. PCBs or assemblies containing XLamp XP Family LEDs should be stacked in a way to allow at least 2 cm clearance above the LED lens.

Do not use bubble wrap directly on top of XLamp XP Family LEDs. Force from the bubble wrap can potentially damage the LED.

✓
CORRECT

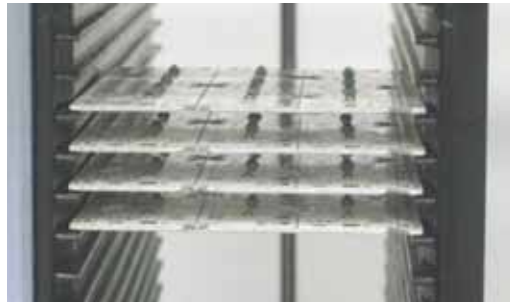

✓
CORRECT

⊘
WRONG





Mechanical Drawings: Tape and Reel

All dimensions in mm.

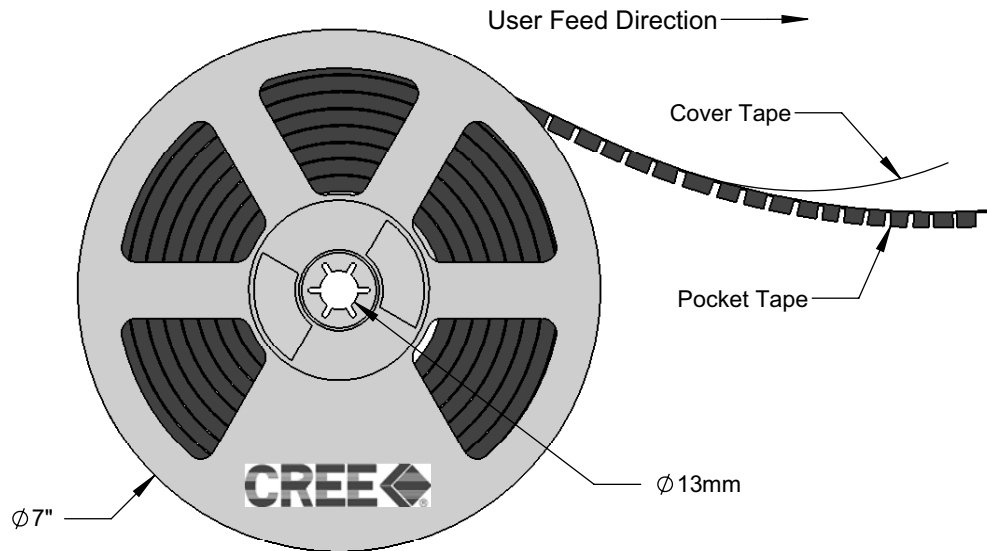
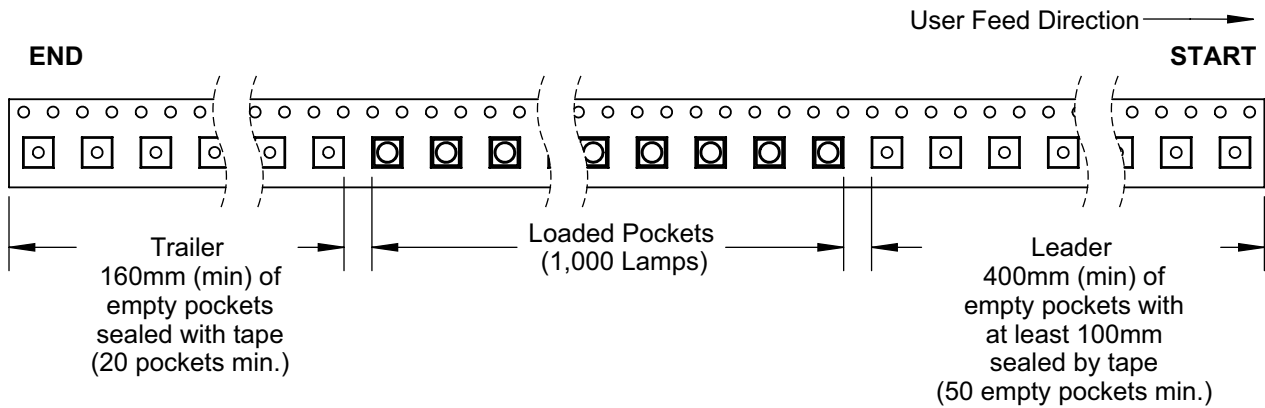
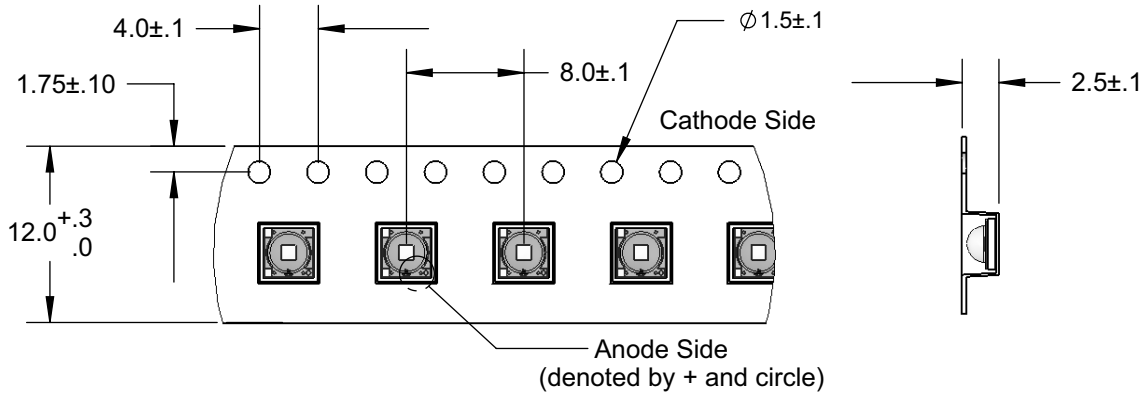

This document is provided for informational purposes only and is not a warranty or a specification. For product specifications, please see the data sheets available at www.cree.com. For warranty information, please contact Cree Sales at sales@cree.com. Copyright © 2008-2009 Cree, Inc. All rights reserved. The information in this document is subject to change without notice. Cree, the Cree logo and XLamp are registered trademarks of Cree, Inc. Other trademarks, product and company names are the property of their respective owners and do not imply specific product and/or vendor endorsement, sponsorship or association.

Cree, Inc.
4600 Silicon Drive
Durham, NC 27703
USA Tel: +1.919.313.5300
www.cree.com/xlamp



Mechanical Drawings: Packaging & Labels

The diagrams below show the packaging and labels Cree will use to ship XLamp XP Family LEDs. XLamp XP Family LEDs are shipped in tape loaded on a reel. Each moisture barrier bag contains only one reel. Each box may contain multiple reels.

