



A New Lighting Experience



- long service lifetime (50,000h)
- very high lumen output
- highly efficient
- easy connections due to GX5.3 base
- connection to 12 V AC (magnetic) and 12 V DC (electronic)
- resistant to shock and vibrations

## LED SpotLight 12 V

**WU-M-333-W/-WW**

### Typical Applications

- Integration in luminaires
- Display case lighting
- Residential lighting
- Furniture lighting
- Energy-efficient alternative for Mains Voltage Halogen Lamps
- Shop design

### Vossloh-Schwabe Deutschland GmbH

Hohe Steinert 8 · 58509 Lüdenscheid, Germany · Phone: +49 (0) 23 51/101-0  
Fax: +49 (0) 23 51/101-217 + -384 · [www.vossloh-schwabe.com](http://www.vossloh-schwabe.com)

# LED SpotLight 12 V

## Technical Notes

- PCB diameter: 38 mm
- Contacts for GX5.3 lampholder
- Voltage supply 12 V AC/DC
- Connection to electronic (DC) and magnetic (AC) ballasts

## Electrical Characteristics

at ambient temperature  $t_a = 25\text{ °C}$

Type	Ref. No.	Colour	Current mA	Voltage supply DC/AC (V)	Power consumption (W)	
					DC	AC
WU-M-333-W	<b>532426</b>	White	150	12	1.8	2.2
WU-M-333-WW	<b>538625</b>	Warm white	150	12	1.8	2.2

## Maximum Ratings

Exceeding the maximum ratings can lead to reduction of lifetime or destruction of the module.

Type	Voltage DC		Voltage AC		Operation temperature at $t_c$ -point		Ambient temperature		Storage temperature range	
	V min.	V max.	V min.	V max.	°C min.	°C max.	°C min.	°C max.	°C min.	°C max.
All types	9	20	10	18	0	+56	-20	+40	-40	+85

## Optical Characteristics

Type	Ref. No.	Colour	Correlated colour temperature (at $t_j^* = 25\text{ °C}$ ) K	Min. luminous flux (at $t_a = 25\text{ °C}$ ) (lm)		Radiation angle (°)
				AC	DC	
WU-M-333-W	<b>532426</b>	White	5650...6950	65	85	25
WU-M-333-WW	<b>538625</b>	Warm white	2720...3040	55	65	25

\*  $t_j$  = junction temperature

## Operating Life

50,000 hrs. (lumen maintenance at 70%,  
in free air-convection);  $t_{a\text{ max.}} = 40\text{ °C}$

This value does not refer to the  
colour temperature.

The values contained in this data sheet can change due to technical innovations. Any such changes will be made without separate notification.  
Please find further detailed information at [www.vsslosh-schwabe.com](http://www.vsslosh-schwabe.com).

# LED SpotLight 12 V

## Typical Light Distribution Curves

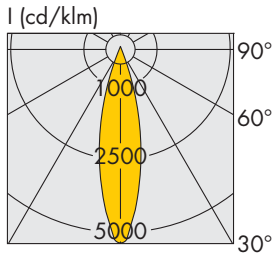

## Mechanical Dimensions

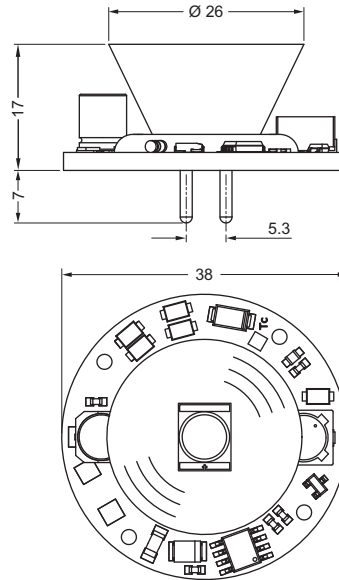

## Bins

The standard shipping format includes all chromaticity coordinate groups. The concrete delivered group is marked on each product packing. Reduction of orderable groups is possible only project-based.

## White

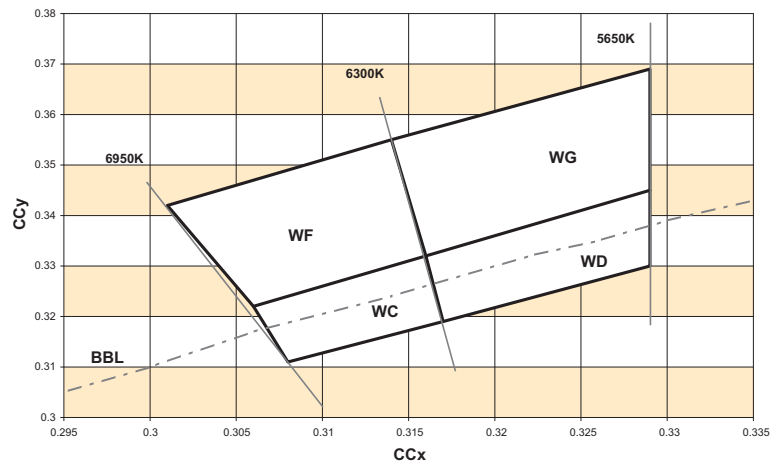

## Warm white

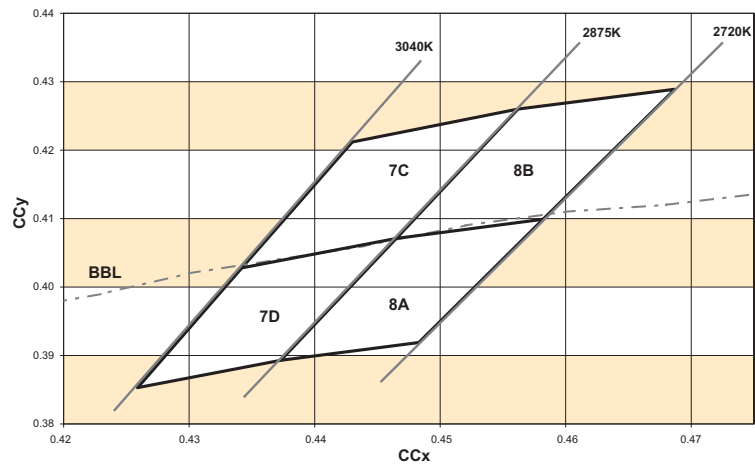

The values contained in this data sheet can change due to technical innovations. Any such changes will be made without separate notification. Please find further detailed information at [www.vsslosh-schwabe.com](http://www.vsslosh-schwabe.com).

# LED SpotLight 12 V

## Assembly and Safety Information

- LED modules and all PCB components must not be subjected to undue mechanical stress:
  - LED modules must not be handled as bulk cargo.
  - Shear and pressure stress must be avoided on LEDs during assembly and handling
- The circuit path must not be damaged or interrupted.
- For easy installation two contacts for GX5.3 lampholders are integrated.
- A safe operation is only possible with electronic DC converters and magnetic AC converters.
- Power supply units must be used for operation, in which the following protective measures are ensured:
  - short-circuit protection
  - overload protection
  - overheating protection
  - SELV equiv. (Safety Extra Low Voltage)
- Safe operation depends on ensuring that the maximum  $t_c$  temperature of 56°C will not be exceeded.
- The maximum output of the power supply must be observed.
- Please ensure standard ESD (electrostatic discharge) protection measures are employed when handling and installing LED modules.
- The modules are not protected against dust or moisture. When LED modules are operated in unduly moist or dusty environments, care must be taken to ensure each module is built into a protective casing in compliance with the correct IP classification or provided with corrosion protection. Damage caused by moisture and/or corrosion will not be recognised as a material or manufacturing defect.
- The LED SpotLight can not be dimmed.
- Do not look directly into the light source
  - glare possible.
- Tests have shown the following chemicals to be harmful to LEDs used on the modules. It is recommended not to use the under-mentioned chemicals anywhere in an LED system. The fumes from even small amounts of these chemicals may damage the LEDs.
  - Chemicals that might outgas aromatic hydrocarbons (e.g., toluene, benzene, xylene)
  - Methyl acetate or ethyl acetate (i.e., nail polish remover)
  - Cyanoacrylates (i.e., "Superglue")
  - Glycol ethers (including Radio Shack®, Precision Electronics Cleaner – dipropylene glycol monomethyl ether)
  - Formaldehyde or butadiene (including Ashland PLIOBOND® adhesive)
  - Dymax 984-LVUF conformal coating
  - Loctite Sumo glue
  - Gorilla glue
  - Clorox bleach
  - Clorox Clean-Up cleaner spray
  - Loctite 384 adhesive
  - Loctite 7387 activator
  - Loctite 242 threadlocker

Detailed information of handling of Cree LEDs can be found on [www.cree.com](http://www.cree.com).