

DigiLED RF CA

WU-ST-012-DigiLED RF CA (Ref. No.: 186181)



A New Lighting Experience

Wall Transmitter

WU-ST-009-Walltransmitter (Ref. No.: 536843)

1 Introduction

1.1 Product description

DigiLED RF CA is designed to enable individual or pre-programmed colour and brightness control of LED assembly modules made by Vossloh-Schwabe (LEDLine Flex RGB CA, Modules of High Power 24 V CA System).

A wall-mounted transmitter (keypad) with 7 keys permits convenient remote control (WU-ST-009-Wall Transmitter Ref. No.: 536843).

2 Description of functions

2.1 Functional characteristics

DigiLED RF CA generates four PWM control signals for colour control of LED modules. The four PWM signals are controlled via an external remote control unit and four pre-set program sequences.

The following functions can be called up using DigiLED RF CA:

- Independent control of individual channel brightness (RGBW),
- Retrieval and storage of individual colour values,
- four different colour sequences (RGB colour sequence, colour sequence with shades of warm white, colour sequence with shades of cool white, RGB colour sequence with fourth channel steadily on 100%) and
- Adjustment of colour sequence speeds.

Should the DigiLED RF CA unit be disconnected from and then reconnected to the mains, the unit will restart with the last-stored colour.

2.2 Synchronizing DigiLED RF CA with a wall transmitter

DigiLED RF CA units and wall transmitters first have to be synchronized before they can communicate with each other. To make duplication impossible, each wall transmitter comes with a unique "rolling code", which must be entered and saved in the DigiLED RF CA unit to enable operation. Before the wall transmitter and DigiLED RF CA can be synchronized, the following steps first have to be completed:

- Open the casing of the wall transmitter and insert the provided battery:
 1. Open cover.
 2. Insert battery, taking care to match polarity (+/-).
 3. Close cover, taking care to ensure the keys are properly enclosed.
- Connect the DigiLED RF CA unit to a 24V DC power source (see 4.)

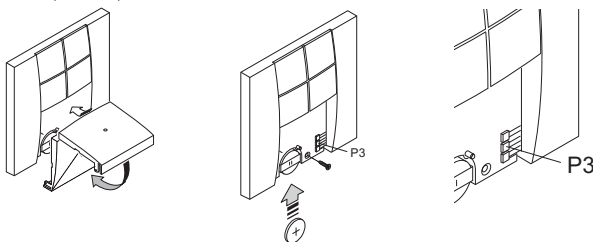

2.2.1 Synchronizing a wall transmitter with a DigiLED RF CA for which no wall transmitter has yet been synchronized (first-time use)

- a) Push P3. The DigiLED RF CA unit will emit a continuous beep for five seconds, which indicates it is ready for synchronizing.
- b) Push the ON/OFF key of the wall transmitter within five seconds of pushing the P3 key. The continuous beep will cease and be replaced by several short beeps. The DigiLED RF CA unit and the wall transmitter have now been synchronized and the functions of the 7 keys can be called up.

The synchronized wall transmitter will now be the "master" transmitter (see 2.2.2), i.e. the only transmitter that can restore the DigiLED RF CA unit to "learning" mode.

Caution: if several DigiLED RF CA are within range of the respective wall transmitter and are connected to a 24 V power supply, the described procedure can result in the other DigiLED RF CA units also being synchronized to the new wall transmitter.

Should the first-synchronized transmitter ("master") be lost or destroyed, no further transmitters can be synchronized to work with the DigiLED RF CA unit. In such an event, a new DigiLED RF CA will have to be installed.

2.2.2 Synchronizing further wall transmitters with a DigiLED RF CA that has already been synchronized with one or more wall transmitters

- a) Push P3 of the already synchronized wall transmitter ("master"). The DigiLED RF CA unit will emit a continuous beep for five seconds, which indicates it is ready for synchronizing.
- b) Press within these five seconds any function button of the master. The beep will be interrupted for one second and then it will start again for five seconds.
- c) Push the ON/OFF key of the new wall transmitter you want to synchronize within 5 seconds. The continuous beep will cease and be replaced by several short beeps. The DigiLED RF CA unit and the wall transmitter have now been synchronized and the functions of the 7 keys can be called up. To synchronize further wall transmitters, please repeat the steps detailed under 2.2.2. Should the first-synchronized transmitter ("master", see 2.2.1) be lost or destroyed, no further transmitters can be synchronized to work with the DigiLED RF CA unit.

Wall Transmitter

WU-ST-009-Walltransmitter (Ref. No.: 536843)

2.2.3 Deleting an already synchronized wall transmitter

- Push P3 three times within the space of three seconds, after which several slow beeps will be emitted.
- Push the ON/OFF key of the wall transmitter you wish to delete: a continuous beep will be emitted indicating that the wall transmitter has been deleted in the DigiLED RF CA unit. To delete further wall transmitters, please repeat the steps detailed under 2.2.3.

2.3 Description of individual functions

The pre-programmed functions of the DigiLED RF CA unit can be called up using the 7 keys of the wall transmitter:

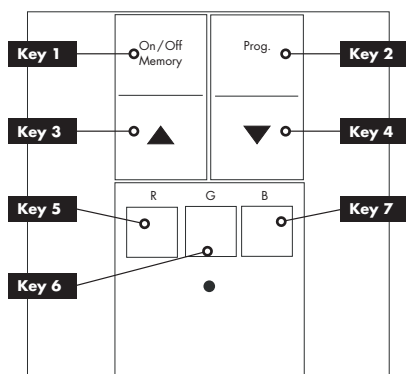

2.3.1 Key 1 (ON/OFF and Save)

Key 1 covers the following functions: switching the connected LED modules "on" or "off" as well as saving current settings (memory).

- Push < 1 s:
ON/OFF. When the unit is switched on, the stored colour value (in line with b) will be called up.
- Push > 3 s:
Push key 1 (> 3 seconds) to save an individual colour value (taken from the programmed sequence or set manually with keys 5, 6 and 7). A brief flashing light indicates that the colour value has been saved.

2.3.2 Key 2 (Program/Dimming Channel 4)

- Briefly push (< 1 s) key 2 to call up various programs. Factory settings encompass an RGB sequence (program 1, figure 1), a colour sequence with warm white shades (program 2, figure 2) and a colour sequence with cool white shades (program 3, figure 2). In the DigiLED RF CA a fourth program is included: RGB sequence (like program 1) with fourth channel (e.g. white) on 100%.

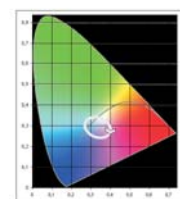
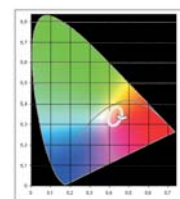
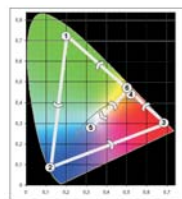

Figure 1: RGB sequence* Figure 2: Warm white* Figure 3: Cool white*

* The diagrams show typical colour sequences that do not necessarily correspond to the actual parameters of individual products. Depending on the respective LED module, the sequences shown can deviate from typical specifications.

Briefly pushing (< 1 s) the key calls up the programs in succession. After pushing the key, the current program is indicated by the flashing light of the respective LED assembly modules:

- single flash for program 1,
 - double flash for program 2,
 - triple flash for program 3 and
 - quadruple flash for program 4.
- Pushing > 2 s addresses the fourth channel (e.g. white). After pushing > 2 s the light intensity of the 4th channel can be increased or decreased by pushing the keys 3 and 4 (see 2.3.3.).

2.3.3 Keys 3 and 4 (Program speed/intensity)

Pushing the "▲" or "▼" key during a colour sequence will either increase or decrease the speed of the colour sequence, whereby the length of time the key is kept depressed will determine the program speed. On reaching an end point (either minimum or maximum speed), the connected module will flash up.

If the respective colour keys (5 = red, 6 = green, 7 = blue, 2 = white) have been pushed first, using the "▲" or "▼" keys will increase or decrease the intensity of the red, green, blue or white light (see 2.3.4).

2.3.4 Keys 5 to 7 (Individual colour modes for red, green and blue)

Briefly pushing key 5 (R = red), 6 (G = green) or 7 (B = blue) addresses the individual colour modules. After pushing keys 5 to 7, the light intensity of the respective colour can be increased or decreased with keys 3 and 4 (see 2.3.3).

DigiLED RF CA

WU-ST-012-DigiLED RF CA (Ref. No.: 186181)



Wall Transmitter

WU-ST-009-Walltransmitter (Ref. No.: 536843)

3 Technical data

3.1 DigiLED RF CA

Operating voltage	23 to 25 V DC
Current draw	max. 5.0 A ± 5 %
Fuse	T5A 250 V microfuse
Connection	8-pin system terminal for operating voltage and LED assembly modules of a 24 V CA system (see Table 4.1)
Ambient temperature	-20 to 45 °C
t_c point temperature	$t_c = 60$ °C max.
Degree of protection	IP20
Casing	Plastic, PC, white
Dimensions (LxWxH)	95 x 60 x 30 mm
Weight	72 g

3.2 Wall Transmitter

Carrier frequency	868.3 MHz
Apparent radiated power	-3 to 1 dBm
Apparent power of harmonics	< 54 dBm (< 4 nW)
Modulation	FSK
Voltage supply	3 V ± 10%
Consumption during transmission	12 mA
Temperature range	-10 to 55 °C
Degree of protection	IP20
Casing	Plastic, PC, white
Dimensions (LxWxH)	86 x 86 x 15 mm
Weight	60 g

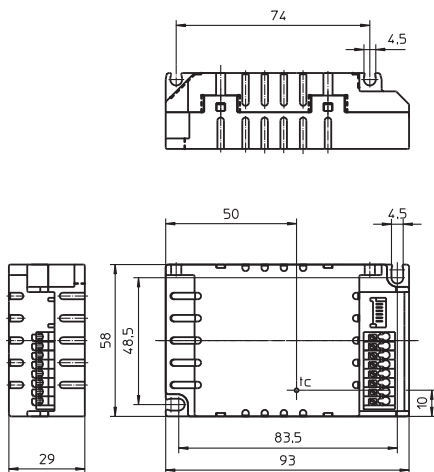

4 DigiLED RF CA connections

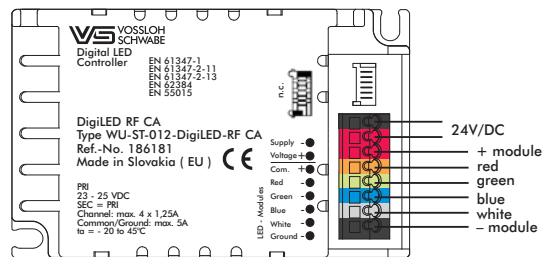

4.1 Terminal Strip for 24 V and Module Connections

Pole	Colour Coding	Max. Current-carrying Capacity	Function	Recommended Lead	Connection
1	● Black	5 A	Supply line for optional 24 V converter (GND)	Standard two-strand supply lead (0.5–1.5 mm ²)	24 V DC converter
2	● Red	5 A	Supply line for optional 24 V converter (+24 V)		
3	● Red	5 A	Supply line for LED assembly modules (+24 V)	High Power Feed-in-cable (Ref. No. 535900)	LED assembly modules or module groups for a 24 CA system
4	● Orange	1.25 A	PWM signal line for channel 1/red		
5	● Green	1.25 A	PWM signal line for channel 2/green	Standard six-strand lead (e.g. UYY 6X0.75 mm ²)	or PCB distributor or slave board for a 24 V CA system
6	● Blue	1.25 A	PWM signal line for channel 3/blue		
7	● Grey	1.25 A	PWM signal line for channel 4/white		
8	● Black	5 A	Supply line for LED assembly modules (GND)		

Wall Transmitter

WU-ST-009-Walltransmitter (Ref. No.: 536843)

5 DigiLED RF CA Connections

5.1 Input

Voltage supply: DigiLED RF CA is supplied with 24 V DC via terminals 1 and 2.

DigiLED Colour control

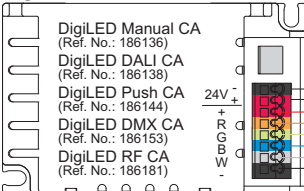

(Layout of connection terminals depend on colour control unit)

Converter LEDLine EDX

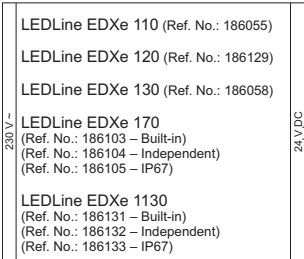

High Power Feed in Ref. No. 535900

5.2 Output

5.2.1 Connection of HighPower 24 V RGB(W) LED Assembly Modules

a) The feed in cable (Ref. No. 535900) must be used to connect a HighPower 24 V RGB(W) LED assembly module. For direct connection, use terminals 3 to 8 of DigiLED RF CA. Correct polarity (colour coding) must be ensure in accordance with table 4.1.

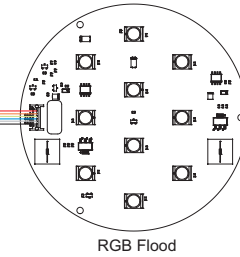

b) To connect several HighPower 24 V RGB(W) LED assembly modules, the PCB distributor (Ref. No. 186141) must be connected to DigiLED RF CA using a standard six-strand lead (e.g. LIYY 6X0.75 mm²).

Correct polarity (colour coding) must be ensured in accordance with Table 4.1. LED assembly modules are connected to the PCB distributor using flatband cables (Ref. No. 535898 or 535899).

DigiLED Colour control

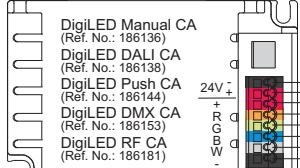

(Layout of connection terminals depend on colour control unit)

Converter LEDLine EDX

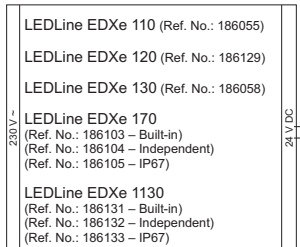

PCB Distributor

High Power Distributor Ref. No. 186141

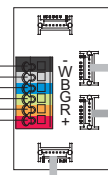

RGB Triple



RGB Line

RGB Flood

— Commercially available e.g. LIYY

— High Power PCB-PCB-connector Ref. No. 535898 (20 mm) Ref. No. 535899 (100 mm)

The maximum number of connected LED assembly modules is limited by the power rating of the converter and by the max. current load of the outputs in accordance with table 4.1. The power and current draw values of the connected LED assembly modules as well as connection cable and PCB distributor data can be found in the respective data sheets at www.vs-optoelectronic.com.

The maximum power rating for a DigiLED RF CA unit totals 120 W.

Wall Transmitter

WU-ST-009-Walltransmitter (Ref. No.: 536843)

c) System performance can be extended beyond 120 W using slave boards to feed in additional power.

Functional descriptions and terminal connections for slave boards can be found in the respective data sheets at www.vs-optoelectronic.com.

Voltage Supply by first Converter

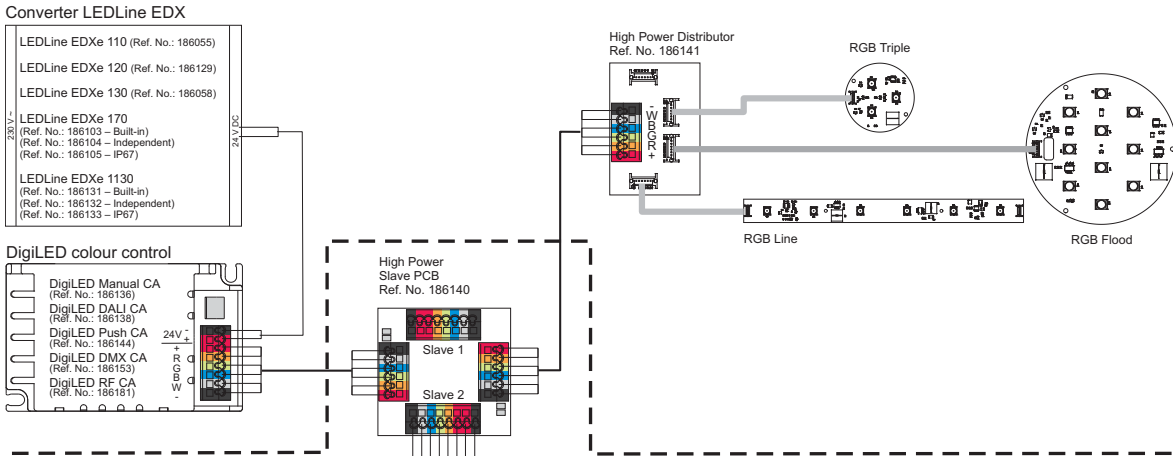

System Expansion by High Power Slave PCB and additional Converter

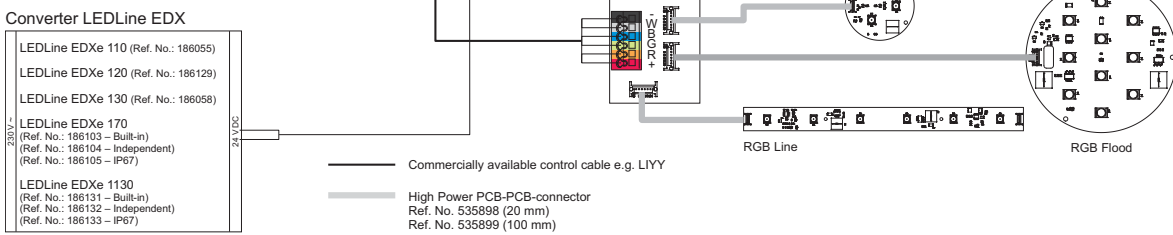

5.2.2 Connection of LowPower 24 V RGB CA Assembly Modules

LowPower 24 V RGB CA LED assembly modules with four connection elements (+RGB) can be directly connected to DigiLED RF CA via poles 3 (+), 4 (red channel), 5 (green channel) and 6 (blue channel) under observation of the permissible power rating. Compliance with the colour coding (polarity) detailed in table 4.1 must be ensured.

The maximum number of connected LowPowerLED assembly modules is limited by the power rating of the connected converter and the maximum current load of pole 4, 5 and 6 (sum: 90 W) in accordance with table 4.1. The power and current draw values of the connected LED assembly modules can be found at www.vs-optoelectronic.com. The maximum power rating with which a DigiLED RF CA unit can be operated totals 90 W.

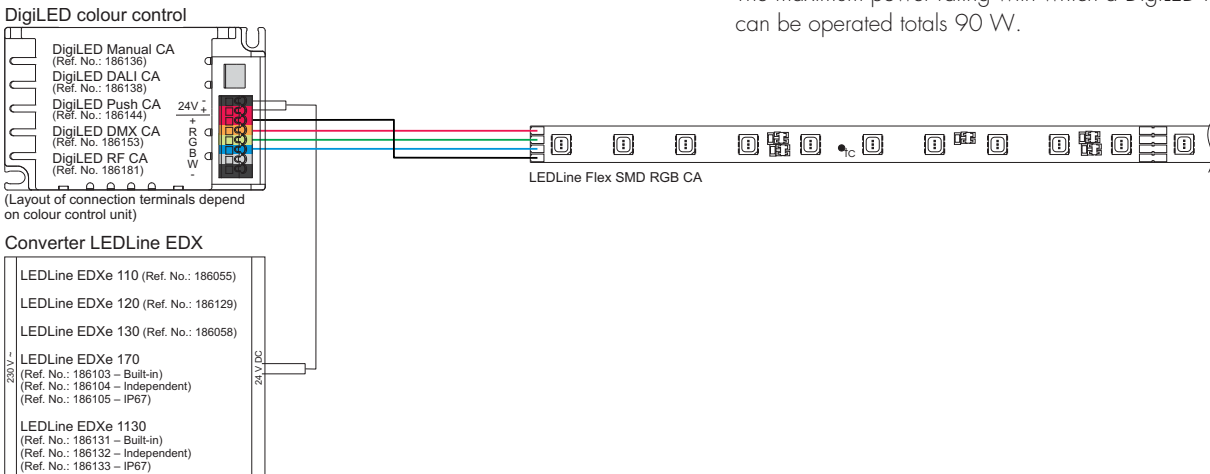

Wall Transmitter

WU-ST-009-Walltransmitter (Ref. No.: 536843)

6 Notes on Installation and Safe Operation

Installation must be carried out under observation of the relevant regulations and standards. The components of the 24 V CA system are designed for operation within a casing or luminaire. Installation must be carried out in a voltage-free state (i.e. disconnection from the mains). The following advice must be observed; non-observance can result in the destruction of the components, fire and/or other hazards.

6.1 DigiLED RF CA

- Do not exceed the load range of the 24 V converter
- Do not exceed the maximum output currents (see table 4.1) per channel
- The temperature measured at the t_c point must not exceed the stipulated maximum value ($t_c \text{ max} = 60 \text{ }^\circ\text{C}$)
- If the DigiLED RF unit is installed in a metal casing or operated in close proximity of increased electromagnetic radiation (e.g. near high-voltage lines), the reception quality of the DigiLED RF CA may be decreased.

6.1.1 Installation of the DigiLED RF

- Can be installed any way up
- The unit must only be operated in dry spaces, luminaires, boxes, casings or the like. When operating DigiLED RF CA units outdoors or in humid rooms, a casing of a suitable (IP) protection class must be used.
- Attach using 4 mm screws.
- Care must be taken to ensure a solid and even surface.

6.2 Wall Transmitter

- The wall transmitter must not be installed for use in buildings or facilities in which radio waves are not permitted for security reasons (e.g. in airports, hospitals).
- Due to the frequency range used by the wall transmitter, the unit may only be used in the following countries: Austria, Belgium, Bulgaria, Cyprus, Czech Republic, Denmark, Eire, Finland, France, Germany, Greece, Hungary, Italy, Latvia, the Netherlands, Norway, Poland, Portugal, Romania, San Marino, Singapore, Slovakia, Slovenia, Spain, Sweden, Switzerland, Turkey, Ukraine and the United Kingdom.
- The user is not protected in any way against interference from devices or telecommunications systems (e.g. radios) that use the same frequency range. In the event of interference that affects the wall transmitter's active range, the wall transmitter should be mounted at a higher point. If necessary, replace the battery to amplify the transmission signal.
- The battery must only be replaced with a CR 2032 battery.
- The battery must be packaged or wrapped both during storage and after its removal from the unit. The battery must not make contact with other metal objects as this could cause the battery to discharge, ignite or be damaged in some other way.
- Damaged or empty batteries must be disposed of immediately in accordance with the respective legal requirements. For advice on safe disposal of batteries, please contact your local environmental protection authority or waste disposal company. Batteries must not be disposed of as part of your household waste.

6.2.1 Mounting of the Wall Transmitter

- Wall-mounted.
- Designed for use in dry spaces only. High humidity levels can cause irreparable damage to the unit.
- Please ensure secure mounting of the wall transmitter to prevent damage from dropping to the ground.

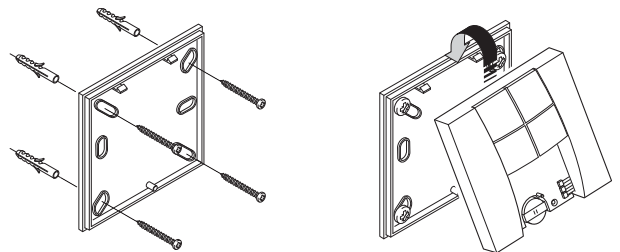

Wall Transmitter

WU-ST-009-Walltransmitter (Ref. No.: 536843)

7

Standards

7.1 DigiLED RF CA

EN 55015

Limits and methods of measurement of radio disturbance characteristics of electrical lighting and similar equipment

7.2 Wall Transmitter

EN 50371

Generic standard to demonstrate the compliance of low power electronic and electrical apparatus with the basic restrictions related to human exposure to electromagnetic fields (10 MHz – 300 GHz) – General public.

EN 60950-1

Information technology equipment – Safety – Part 1: General requirements

ETS 301 489-1/-3

Electromagnetic compatibility and Radio spectrum Matters (ERM) – Electro Magnetic Compatibility (EMC) standard for radio equipment and services – Part 1: Common technical requirements.

Part 3: Specific conditions for Short-Range Devices (SRD) operating on frequencies between 9 kHz and 40 GHz.

EN 300 220-1/-3

Electromagnetic compatibility and Radio Spectrum Matters (ERM) – Short Range Devices (SRD) – Radio equipment to be used in the 25 MHz to 1000 MHz frequency range with power levels ranging up to 500 mW – Part 1: Technical characteristics and test methods.

Part 3: Harmonized EN covering essential requirements under article 3.2 of the R&TTE Directive.