

# DigiLED Mono CA

WU-ST-010-DigiLED-Mono CA (Ref. No.: 186155)

## 1 Introduction

### 1.1 Product Description

DigiLED Mono CA units are designed for dimming monochrome LED modules used with 24 V LED CA assembly systems and standard 24 V systems. The dimming function can be achieved using a 1–10 V interface or via an external PWM signal (e. g. supplied by a DigiLED DALI CA unit). As a system control device, DigiLED Mono CA serves to control the brightness of high- and/or low-power LED modules that can either be of common anode (CA) design or have two connecting leads (+24 V and –).

## 2 Description of Functions

### 2.1 Functional Characteristics

DigiLED Mono CA generates a PWM signal to dim monochromatic 24 V LED modules. The control signal is addressed via a 1–10 V interface or an external PWM control channel.

The following DigiLED Mono CA functions can be adjusted:

- Dimming of 24 V LED modules via a 1–10 V interface
- Dimming of 24 V LED modules via an external PWM control signal (e.g. supplied by the DigiLED CA system) to achieve an output current of 5 A maximum.
- Dimming of LED modules with only two connecting leads: + 24 V and – (e.g. LEDline Flex in white or warm white).
- Dimming of common anode (CA) LED modules (e.g. HighPower 24 V CA white).

## 3 Technical Specifications

Operating Voltage	23 to 25 V DC
Current draw	max. 5 A
Fuse	T 5 A 250 V microfuse
Connection	6-pin push-in terminal for LED assembly modules (see table 4.2) 6-pin push-in terminal for input configuration (see table 4.1)
Ambient temperature	–20 °C to +45 °C
$t_c$ point	max. 55 °C
Degree of Protection	IP20
Casing	Plastic, PA, white
Dimensions (LxWxH)	83 x 30 x 19 mm
Weight	23 g

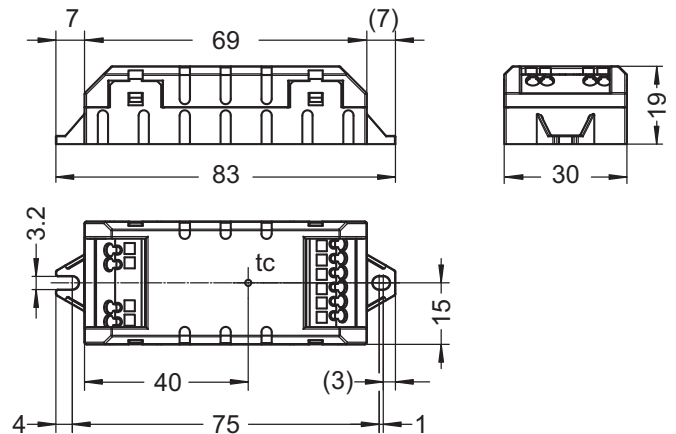

# DigiLED Mono CA

WU-ST-010-DigiLED-Mono CA (Ref. No.: 186155)



## 4 Terminal Connections

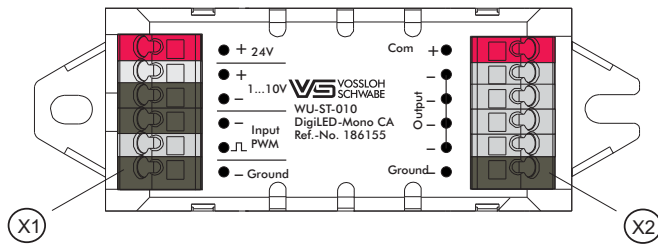

### 4.1 Terminal Strip Input (X1)

Terminal	Colour Coding	Max. Current-carrying Capacity	Function	Recommended Lead	Connection
1	● Red	5 A	Supply line 24 V converter (+24 V)	Standard two-strand lead (0.25–1.5 mm <sup>2</sup> )	24 V DC converter
2	● Grey	n.a.	+ Terminal of the 1–10 V* low-voltage interface	Standard installation material	1–10 V controller
3	● Black	n.a.	– Terminal of the 1–10 V* low-voltage interface		To the GND of the chosen voltage sources
4	● Black	n.a.	Ground connection by using different converters (see 5.1)		
5	● Grey	n.a.	Input of external PWM signal (see 5.1); PWM frequency = 1 kHz max.	Standard two-strand lead (0.25–1.5 mm <sup>2</sup> )	24 V DC converter
6	● Black	5 A	Supply line 24 V converter (GND)		

\* Signal current of the 1–10 V interface: max. 500 µA

### 4.2 Terminal Strip Output (X2)

Terminal	Colour Coding	Max. Current-carrying Capacity	Function	Recommended Lead	Connection
1	● Red	5 A	Supply line for LED assembly modules (+24 V)	High Power Feed-in cable (Ref. No. 535900)	LED assembly modules or module groups for 24 V CA system, or for bipolar 24 V LED modules
2	● Grey	5 A in total	PWM output		
3	● Grey	(terminals are bypassed)			
4	● Grey				
5	● Grey				or distributor or slave board for the 24 V CA system
6	● Black	5 A	Supply line for LED assembly modules (GND)		

## 5 DigiLED Mono CA Connections

### 5.1 Input

#### 5.1.1 Voltage supply:

DigiLED Mono CA units are supplied with 24 V DC via terminals 1 and 6 of an X1 terminal block.

#### 5.1.2 1–10 V input:

1–10 V dimmers are connected via terminals 2 and 3 of an X1 terminal block.

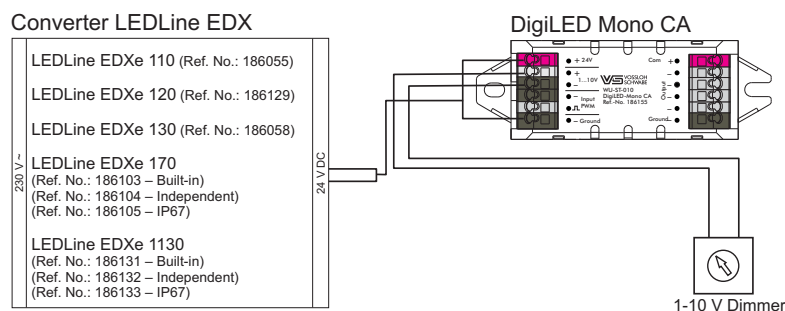

Vossloh-Schwabe Deutschland GmbH

Hohe Steinert 8 · 58509 Lüdenscheid, Germany · Phone: +49/23 51/101-0 · Fax: +49/23 51/101-217 + -384 · www.vossloh-schwabe.com

# DigiLED Mono CA

WU-ST-010-DigiLED-Mono CA (Ref. No.: 186155)



## 5.1.2.1 System extension

System extension example (assuming suitable 1–10 V  
controllers are used; 500 µA per DigiLED Mono CA):

By using the VS dimmer (Ref. No. 172778) up to 50 DigiLED  
Mono CA modules can be operated.

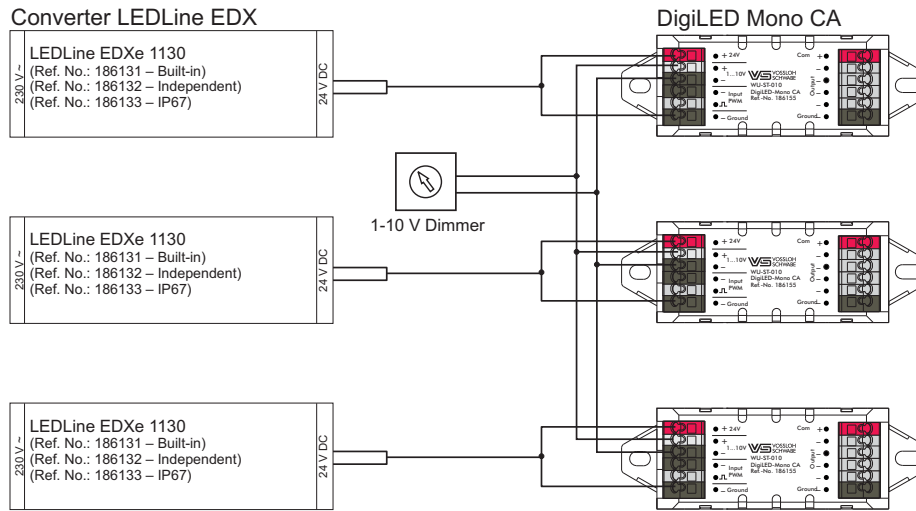

## 5.1.3 External PWM output:

An external PWM signal can be connected to terminal 5  
(X1 block). In order to use the PWM input, the 1–10 V input  
(terminals 2 and 3 of X1) has to be bypassed:

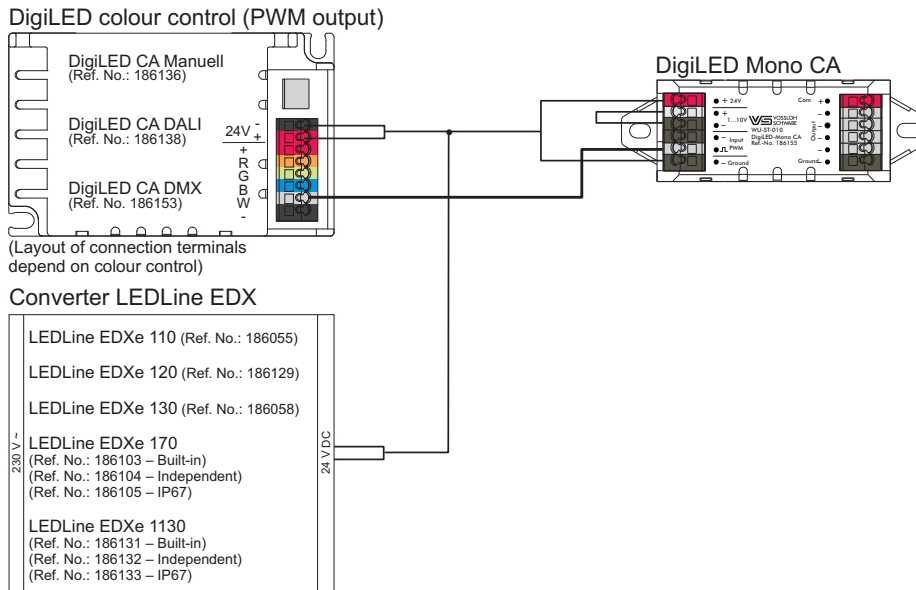

# DigiLED Mono CA

WU-ST-010-DigiLED-Mono CA (Ref. No.: 186155)

## 5.1.3.1 Use of different converters

If different converters are used, it is necessary to ensure potential equalisation (GND connection) via terminal 4 (of the X2 block).

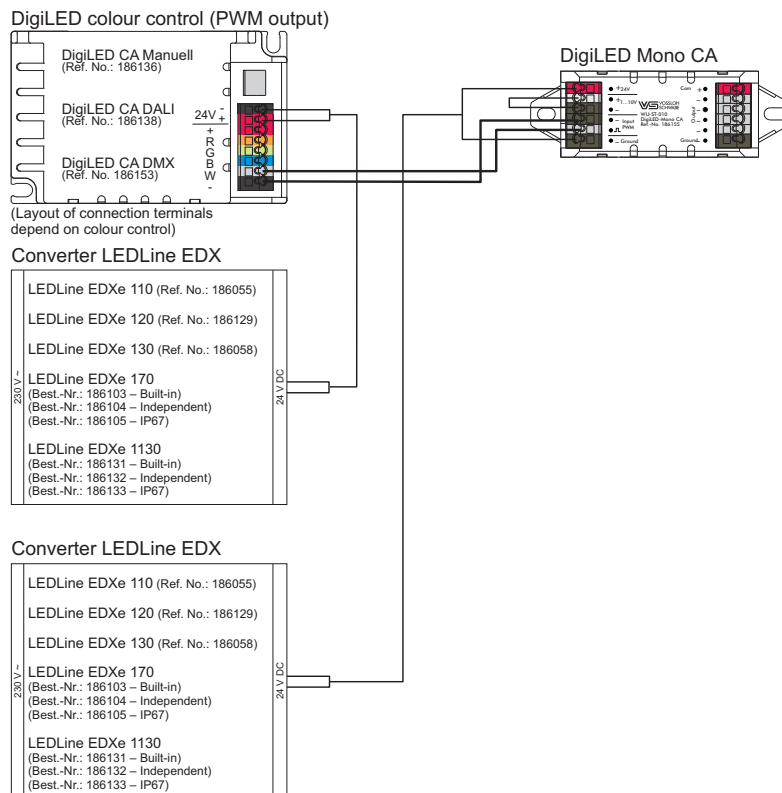

## 5.2 Output

### 5.2.1 Connection of single-colour HighPower 24 V LED assembly modules

a) A feed-in cable (Ref. No. 535900) must be used to connect single-colour HighPower 24 V LED assembly modules. DigiLED Mono CA units can be directly connected to terminals 1 to 6 of the X2 terminal block. In line with Table 4.2, care must be taken in this respect to ensure the supply line to the LED assembly module

(red for +24 V and black for -) is connected to the correct terminals (1 and 6) of the X2 terminal block. Terminals 2 to 5 of the X2 terminal block are bypassed in the case of a DigiLED Mono CA unit so that the channel can be freely chosen.

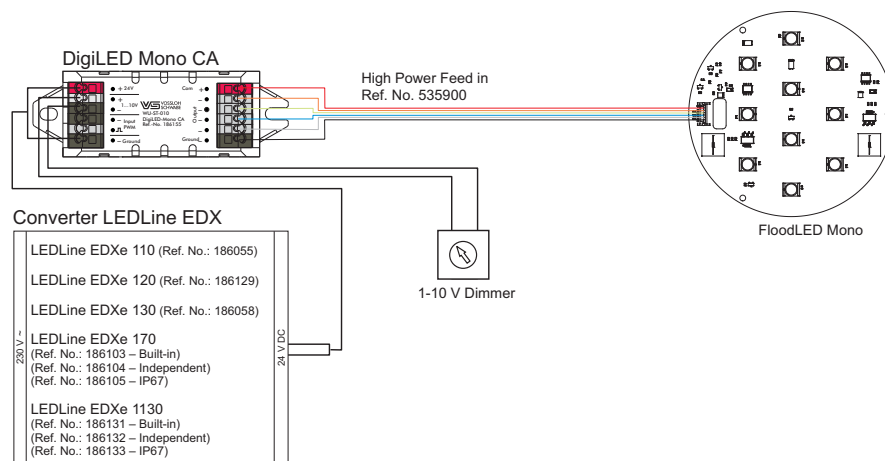

# DigiLED Mono CA

WU-ST-010-DigiLED-Mono CA (Ref. No.: 186155)



## 5.2.1 Connection of single-colour HighPower 24 V LED assembly modules

b) To connect several monochrome HighPower 24 V LED assembly modules, the distributor board (Ref. No. 186141) must be connected to the DigiLED Mono CA unit using a commonly available 3- to 6-strand lead (e.g. LiYY 3X0.75 mm<sup>2</sup>). Care must be taken to exactly match the polarity of the red and black terminals when connecting a DigiLED Mono CA unit to a distributor board. The number of leads supplying the PWM signal is determined by the number of different colours that need to be

dimmed. The diagram shows a circuit in which only white LEDs are wired for dimming. Alternatively, it is equally possible to dim blue LED assembly modules, for instance. In such a case, the PWM output of the DigiLED Mono CA unit must be be connected to the blue terminal of the distributor board. Detailed information on the distributor board can be found at [www.vs-optoelectronic.com](http://www.vs-optoelectronic.com).

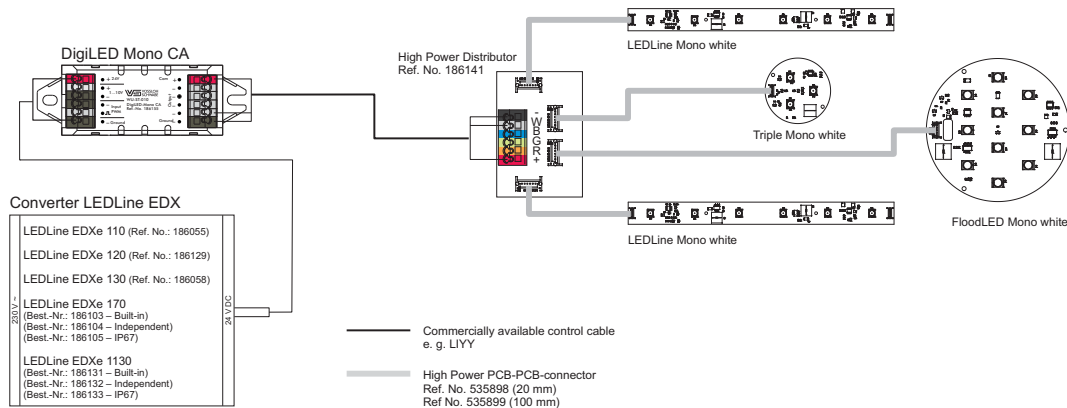

The maximum number of connected LED assembly modules is limited by the power rating of the connected converter and by the max. current load of channels 1 to 6 of terminal X2 (sum: 120 W) in accordance with Table 4.2. The power and current draw values of the connected LED assembly modules can be found at [www.vs-optoelectronic.com](http://www.vs-optoelectronic.com).

c) To increase system output over 120W, slave boards can be used to feed-in additional power. Information on functions and terminal connections of slave boards can be found in the respective data sheets at [www.vs-optoelectronic.com](http://www.vs-optoelectronic.com).

### Voltage supply by first 24 V converter

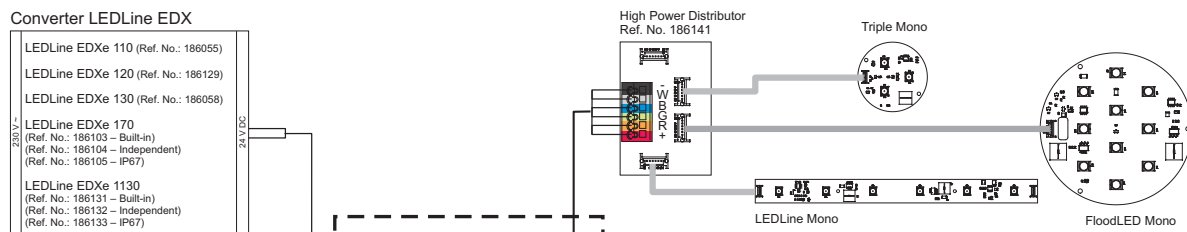

### System expansion by High Power Slave PCB and additional 24 V converter

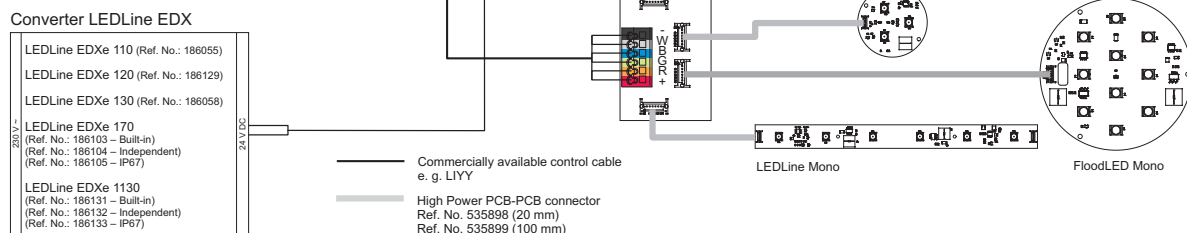

# DigiLED Mono CA

WU-ST-010-DigiLED-Mono CA (Ref. No.: 186155)



## 5.2.2 Connection of 24 V LED assembly modules with 2 connecting leads (+24 V and -)

To connect a 24 V LED assembly module with just two connecting leads (+24 V and -), the + pole must be connected to terminal 1 of the X2 terminal block and the - pole connected to one of terminals 2 to 5 of the X2 terminal block. The maximum number of connected LED assembly modules is limited by the converter rating and by the maximum current-carrying capacity of terminals 1 to 5 of an X2 terminal block (120 W max.) in accordance with Table 4.2. Power and current consumption values relating to LED assembly modules can be found at [www.vs-optoelectronic.com](http://www.vs-optoelectronic.com).

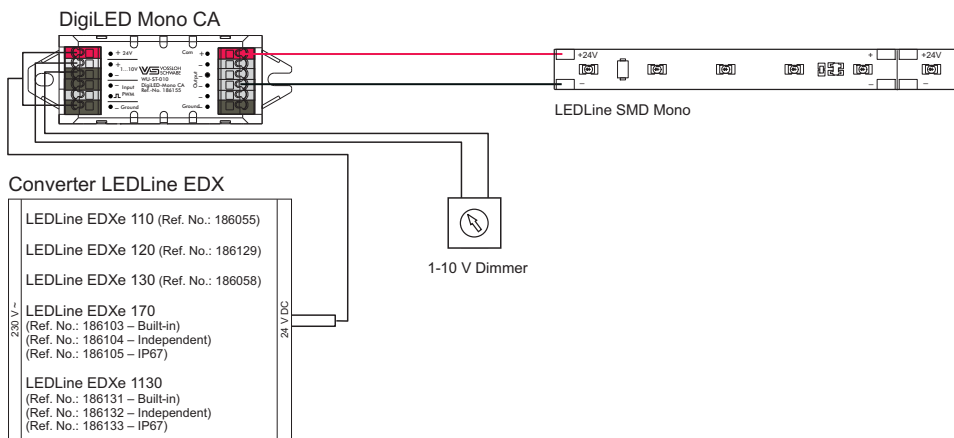

## 6 Notes on Installation and Safe Operation

### 6.1 Installation

Installation must be carried out under observation of the relevant regulations and standards. DigiLED Mono CA devices are designed for operation within a casing or luminaire. Installation must be carried out in a voltage-free state (i. e. disconnection from the mains). The following advices must be observed; non-observance can result in the destruction of the components, fire and/or other hazards:

- The load range of the connected 24 V converter must be observed
- The maximum output currents specified in Table 4.2 must not be exceeded
- The temperature measured at the  $t_c$  point must not exceed the specified limit ( $t_c$  max. = 55° C) during operation

### 6.2 Assembly

- Installation any way up
- Installation only in dry rooms or luminaires, box casings or similar. If DigiLED mono is to be installed outdoors or in a damp location, a casing of a suitable protection class (IP) must be used
- Attach using 3 mm or 4 mm screws
- Ensure solid and even surface for unit to rest on

## 7 Standards

### 7.1 Applied Standards

EN 61347-1  
Lamp controlgear – Part 1: General requirements and tests (IEC 61347-1:2000);  
German Version EN 61347-1:2001  
EN 61347-2-11  
Lamp controlgear – Part 2-11: Particular requirements for miscellaneous electronic circuits used with luminaires (IEC 61347-2-11:2001);  
German Version EN 61347-2-11:2001  
EN 55015  
Limits and methods of measurement of radio disturbance characteristics of electrical lighting and similar equipment

### 7.2 Standards to be adhere

EN 61347-2-13  
Lamp controlgear – Part 2-13: Particular requirements for D.C. or A.C. supplied electronic controlgear for LED modules  
EN 62384  
D.C. or A.C. supplied electronic control gear for LED modules – Performance requirements