

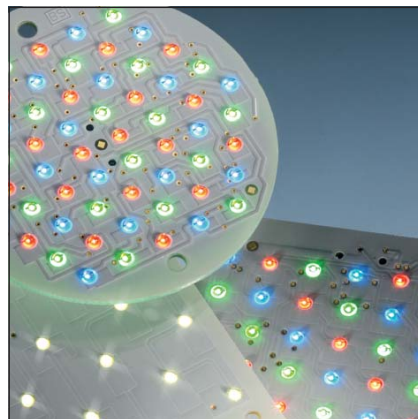

A New Lighting Experience



- high quality due to Chip-on-Board technology
- available in monochrome and RGB
- resistant against shock and vibrations
- low mounting height
- low heat development
- lead-free soldered

## MarkerLED

**WU-M-245, WU-M-246, WU-M-267**

### Typical Applications

- Marking paths, stairs, etc.
- Furniture lighting
- Light advertising
- Entertainment, shop design
- Architectural illumination

### Vossloh-Schwabe Deutschland GmbH

Hohe Steinert 8 · 58509 Lüdenscheid, Germany · Phone: +49 (0) 23 51/101-0  
Fax: +49 (0) 23 51/101-217 + -384 · [www.vossloh-schwabe.com](http://www.vossloh-schwabe.com)

# MarkerLED

## Technical Notes

- WU-M-245: round, Ø 50 mm
- WU-M-246: round, Ø 80mm
- WU-M-267: square, L x W = 75 mm x 88 mm
- LED-chips are driven by constant current sources
- Wide radiation angle (170°) due to Chip-on-Board technology
- Voltage supply: 24 V DC

## Electrical Characteristics

at ambient temperature  $t_a = 25\text{ °C}$

Type	Ref. No.	Colour	Number of LEDs	Current* mA	Voltage DC* V	Power* W	Max. quantity of modules ** pcs.
<b>MarkerLED Ø 50 mm</b>							
WU-M-245-RGB	<b>527288</b>	RGB	30	75	24	1.80	32
WU-M-245-SO	<b>527291</b>	Red	30	60	24	1.44	48
WU-M-245-SG	<b>527290</b>	Green	30	90	24	2.16	32
WU-M-245-SB	<b>527289</b>	Blue	30	90	24	2.16	32
WU-M-245-SY	<b>527393</b>	Yellow	30	60	24	1.44	48
WU-M-245-W-54	<b>527629</b>	White	30	90	24	2.16	32
<b>MarkerLED Ø 80 mm</b>							
WU-M-246-RGB	<b>527292</b>	RGB	60	150	24	3.60	16
WU-M-246-SO	<b>527295</b>	Red	60	120	24	2.88	24
WU-M-246-SG	<b>527294</b>	Green	60	180	24	4.32	16
WU-M-246-SB	<b>527293</b>	Blue	60	180	24	4.32	16
WU-M-246-SY	<b>527394</b>	Yellow	56	120	24	2.88	24
WU-M-246-W-54	<b>527630</b>	White	60	180	24	4.32	16
<b>MarkerLED square</b>							
WU-M-267-RGB	<b>525641</b>	RGB	56	200	24	4.80	12
WU-M-267-SO	<b>525645</b>	Red	25	60	24	1.44	16
WU-M-267-SG	<b>525642</b>	Green	25	100	24	2.40	10
WU-M-267-SB	<b>525643</b>	Blue	25	100	24	2.40	10
WU-M-267-SY	<b>525646</b>	Yellow	25	60	24	1.44	16
WU-M-267-W-54	<b>525644</b>	White	25	100	24	2.40	10

## Maximum Ratings

Exceeding the maximum ratings can lead to reduction of lifetime or destruction of the module.

Type	Voltage DC		Operation temperature range at $t_c$ -point		Storage temperature range		Reverse voltage/LED V
	V min.	V max.	°C min.	°C max.	°C min.	°C max.	
All types	23	25	-20	+65	-20	+85	5

\* On account of the complex manufacturing process of the modules the above values only represent statistical variables.

The values do not necessarily correspond exactly to the actual parameters of every single product which can vary from the typical specification.

\*\* By the use of the DigiLED Slave the quantity of modules can be increased further.

# MarkerLED

## Optical Characteristics

at ambient temperature  $t_a = 25\text{ °C}$

Type	Ref. No.	Colour	Dom. wavelength* (nm)			Luminous flux*	Radiation angle*
			Colour temperature* (K)			lm	°
<b>MarkerLED Ø 50 mm</b>							
WU-M-245-RGB	<b>527288</b>	RGB	R 625	G 535	B 470	43	170
WU-M-245-SO	<b>527291</b>	Red	625			35	170
WU-M-245-SG	<b>527290</b>	Green	535			38	170
WU-M-245-SB	<b>527289</b>	Blue	470			12	170
WU-M-245-SY	<b>527393</b>	Yellow	590			30	170
WU-M-245-W-54	<b>527629</b>	White	5400K			33	170
<b>MarkerLED Ø 80 mm</b>							
WU-M-246-RGB	<b>527292</b>	RGB	R 625	G 535	B 470	86	170
WU-M-246-SO	<b>527295</b>	Red	625			70	170
WU-M-246-SG	<b>527294</b>	Green	535			77	170
WU-M-246-SB	<b>527293</b>	Blue	470			24	170
WU-M-246-SY	<b>527394</b>	Yellow	590			60	170
WU-M-246-W-54	<b>527630</b>	White	5400K			65	170
<b>MarkerLED square</b>							
WU-M-267-RGB	<b>525641</b>	RGB	R 625	G 535	B 470	55	170
WU-M-267-SO	<b>525645</b>	Red	625			37	170
WU-M-267-SG	<b>525642</b>	Green	535			45	170
WU-M-267-SB	<b>525643</b>	Blue	470			13	170
WU-M-267-SY	<b>525646</b>	Yellow	590			25	170
WU-M-267-W-54	<b>525644</b>	White	5400K			45	170

\* Due to the special conditions of the manufacturing process the typical data of technical parameters can only reflect statistical figures and do not necessarily correspond to the actual parameters of each single product which could differ from the typical data.

## Light Distribution Curves

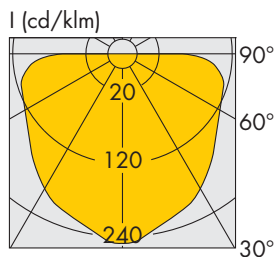

**WU-M-245/-246/-267/-RGB, -SO, -SG, -SB, -W**

# MarkerLED

## Mechanical Dimensions

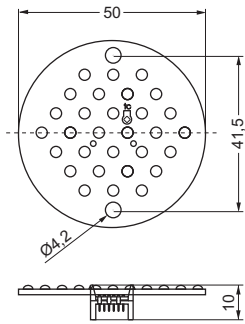

**WU-M-245**

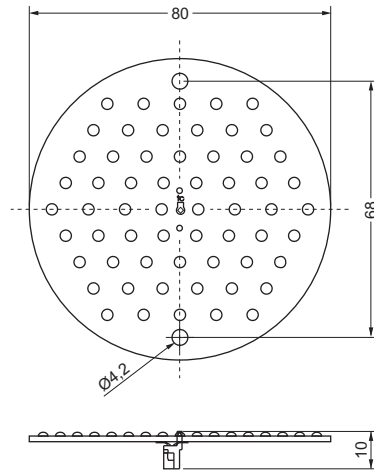

**WU-M-246**

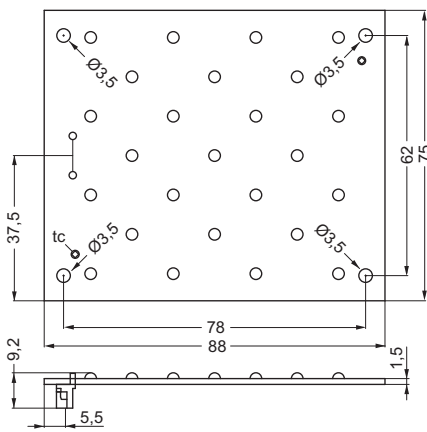

**WU-M-267 Mono**

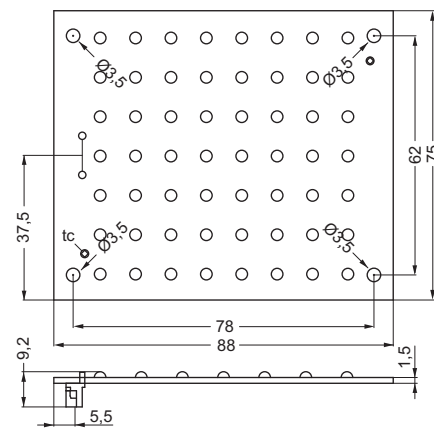

**WU-M-267 RGB**

# MarkerLED

## Assembly and Safety Information

- LED modules and all PCB components must not be subjected to undue mechanical stress:
  - LED modules must not be handled as bulk cargo
  - Shear and pressure stress must be avoided on the grouting material of LEDs during assembly and handling
- The circuit path must not be damaged or interrupted.
- Power supply units must be used for operation, in which the following protective measures are ensured:
  - Short-circuit protection
  - Overload protection
  - Overheating protection
  - SELV equiv. (Safety Extra Low Voltage)
- The maximum output of the power supply must be observed.
- The modules can be wired by the use of commercial 6-strand flatband cable.
- For colour mixing colour control modules of the DigiLED series (DigiLED-Manuel, DigiLED-Wireless-IR, DigiLED-1–10 V, DigiLED-DMX) must be used. Information about the connection technique can be found in the manuals of the DigiLED series ([www.vs-optoelectronic.com](http://www.vs-optoelectronic.com)).
- Please ensure standard ESD (electrostatic discharge) protection measures are employed when handling and installing LED modules. Electrostatic discharge can damage LEDs.
- The modules are not protected against dust or moisture. When LED modules are operated in unduly moist or dusty environments, care must be taken to ensure each module is built into a protective casing in compliance with the correct IP classification or provided with corrosion protection. Damage caused by moisture and/or corrosion will not be recognised as a material or manufacturing defect.
- Contact with chemicals containing acid or acetic acid can permanently damage LEDs. Substances and materials containing acid or acetic acid must therefore not be used for cleaning, maintaining and installing LED modules or LED luminaires. The vapours produced by such chemicals alone can damage LEDs.
- Fixing holes (Ø 4.2 mm, Ø 3.5 mm WU-M-267) are integrated on the PCBs for easy assembly. Please use for installation spacers (min. 7 mm) and plastic screws for assembly in order to avoid short circuits or damage. Make sure not to destroy the PCB during fixing.