



A New Lighting Experience



- ultra long lifetime
40,000 h
- no binnings
- very high CRI: $R_a \approx 90$
- very homogeneous light spot
- low energy consumption
(8W/16W)
- highly efficient, high brightness
- compact design; new flat shape
- RoHS-compliant

VS-P3

Cool white and warm white (wide and narrow angle)

Typical Applications

- Built-in luminaires / general illumination:
 - reading lights
 - desk lights
 - down lights
- High CRI applications
 - merchandise illumination
 - art illumination
 - colour inspection

Vossloh-Schwabe Deutschland GmbH

Hohe Steinert 8 · 58509 Lüdenscheid, Germany · Phone: +49 (0) 23 51/101-0
Fax: +49 (0) 23 51/101-217 + -384 · www.vossloh-schwabe.com

VS-P3

Technical Notes

VS-P3 Spotlight:

- Dimension: Ø46.8x20 mm (dia. x height)
- Power consumption: max. 8W
- Driving current: 500mA DC

VS-P3 Downlight:

- Dimension: Ø58.5x15.7 mm (dia. x height)
- Power consumption: max. 16W
- Driving current: 500mA DC

Electrical Characteristics

at t_c (aluminum body) = 80 °C

Type	Number of light points	Max. current mA	Max. voltage DC			Max. power W
			min. (V)	typ. (V)	max. (V)	
VS-P3 Spotlight						
All types	4	500	10	14.3	16	8
VS-P3 Downlight						
All types	8	500	21	28.5	32	16

Maximum Ratings

Exceeding the maximum ratings can lead to reduction of lifetime or destruction of the module.

Type	Operation temperature range at aluminum body		Storage temperature range		Junction temperature range	
	°C min.	°C max.	°C min.	°C max.	°C min.	°C max.
All types	-20	+100	-30	+100	-30	+105

Optical Characteristics

$I_F = 500\text{mA}$; t_c (aluminum body) = 80°C

Type	Ref. No.	Colour	Beam	Radiation angle (°)			Luminous flux (lm)		Colour rendering index R_a	
				min.	typ.	max.	min.	typ.	min.	typ.
VS-P3 Spotlight										
NKB 94510-CW	534511	Cool white	narrow	27	30	33	207	230	87	90
NKB 94511-WW	534512	Warm white	narrow	27	30	33	162	180	87	90
VS-P3 Downlight										
NKB 98510-CW	534513	Cool white	narrow	42	45	48	389	432	87	90
NKB 98520-CW	534514	Cool white	wide	67	70	73	374	415	87	90
NKB 98511-WW	534515	Warm white	narrow	42	45	48	311	346	87	90
NKB 98521-WW	534516	Warm white	wide	67	70	73	299	332	87	90

Chromaticity Coordinate

Colour	Chromaticity coordinate				
	Cx	Cy	Cz	u'	v'
Cool white	Cx	0.340	0.355	0.355	0.340
	Cy	0.347	0.359	0.382	0.370
Warm white	Cx	0.435	0.465	0.465	0.435
	Cy	0.403	0.412	0.425	0.419

Operating Life

40,000 hrs. (lumen maintenance at 70%,
 t_c [aluminum body] = 80°)

Bins

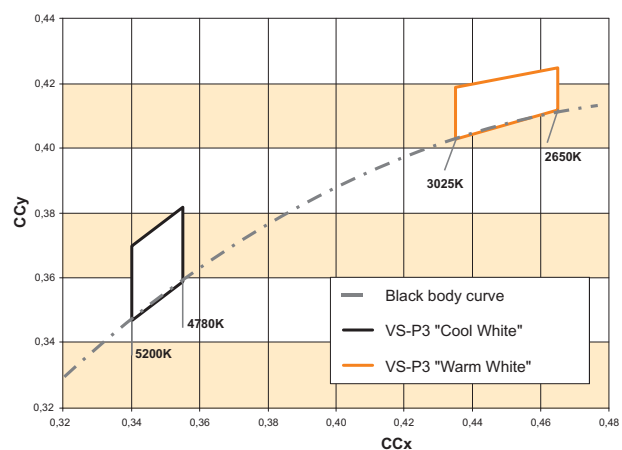

The values contained in this data sheet can change due to technical innovations. Any such changes will be made without separate notification. Please find further detailed information at www.vs-optoelectronic.com.

VS-P3

Illuminance (E_v) in lux

Type	Ref. No.	Distance			
		0.3 m	0.5 m	1 m	2 m
VS-P3 Spotlight					
NKB 94510-CW	534511	5334	2268	567	142
NKB 94511-WW	534512	4223	1783	446	112
VS-P3 Downlight					
NKB 98510-CW	534513	6703	2461	615	154
NKB 98520-CW	534514	3313	1214	304	76
NKB 98511-WW	534515	5399	2032	508	127
NKB 98521-WW	534516	2703	990	247	62

Typical Light Distribution Curves

I (cd/klm) – Spotlight/30°

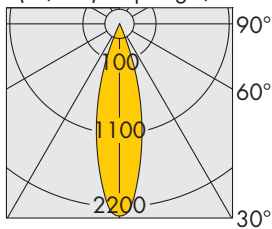

I (cd/klm) – Downlight/45°

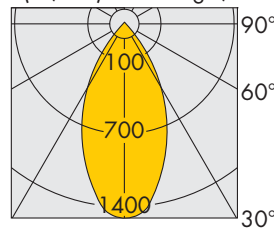

I (cd/klm) – Downlight/70°

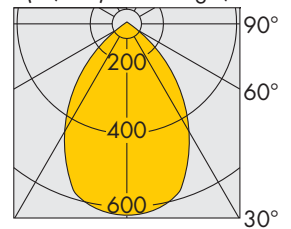

Mechanical Dimensions

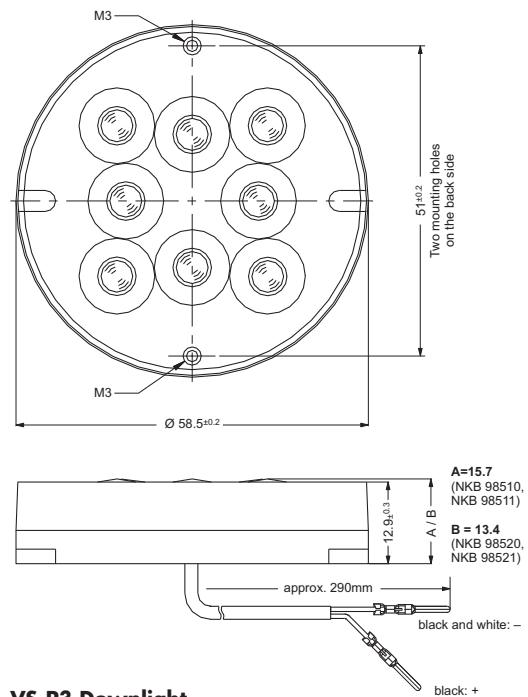
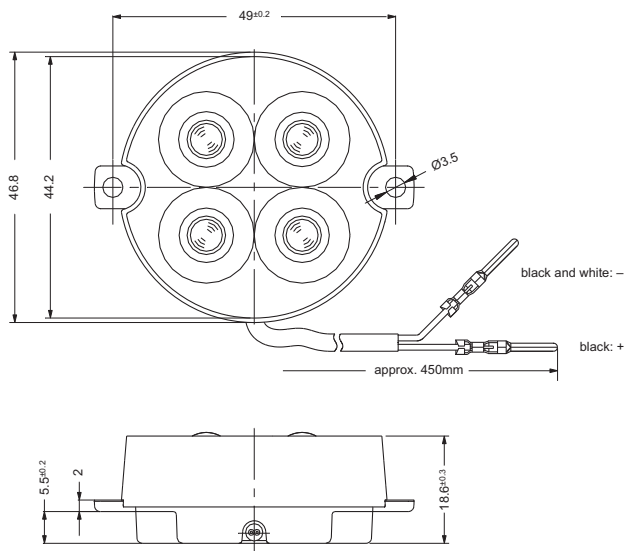

VS-P3 Spotlight

VS-P3 Downlight

The values contained in this data sheet can change due to technical innovations. Any such changes will be made without separate notification. Please find further detailed information at www.vs-optoelectronic.com.

VS-P3

Safety Information

- Warning: the installation of LED modules may only be undertaken by qualified staff. Installation must be conducted at zero potential after disconnection from the mains.
- The VS-P3 modules can get hot. Please provide warning notices if necessary.

Assembly and Handling Information

- LED modules and all PCB components must not be subjected to undue mechanical stress:
 - LED modules must not be handled as bulk cargo.
- The LED modules are not protected against short-circuiting, overloading or overheating. The use of Vossloh-Schwabe electronic power supply units is therefore absolutely essential. For safe operation please use ECXe 500mA driver (Ref. No.: 186134).
- Please ensure standard ESD (electrostatic discharge) protection measures are employed when handling and installing LED modules. Electrostatic discharge can damage LEDs.
- Please ensure the correct polarity of the leads prior to commissioning. Reversed polarity can destroy the modules.
Lead identification:
black and white: –
black: +
- The modules are not protected against dust or moisture. When LED modules are operated in unduly moist or dusty environments, care must be taken to ensure each module is built into a protective casing in compliance with the correct IP classification. Damage caused by moisture and/or corrosion will not be recognised as a material or manufacturing defect.
- To ensure smooth module operation, care must be taken that module temperatures at the aluminum body (t_c) never exceed the maximum values stipulated in this data sheet.
- Due to the numerous installation options and differing operating conditions, no precise installation guidelines can be provided that will ensure the maximum temperature values are never exceeded. In principle, the modules can be mounted on an aluminum luminaire casing to ensure the generated heat can be dissipated to the surroundings.